

Job Name:	
Submitted By:	



**Submittal Sheet For: WT012GLSI25HLH / YN012GLSI25RPH**

Date \_\_\_\_\_  
 Ref. \_\_\_\_\_

**Wall-Mounted Ductless 25SEER Inverter Heat Pump**

System Full Set Model: **WYT012GLSI25RH**

AHRI Reference Number: **217048755**

**Cooling Mode Performance**

Rated Cooling	12,000 BTU/hr
Ambient Range	5~131°F
SEER2 Rating	25.0 BTU/W·h
EER2 Rating	14.0 BTU/W·h

\* 100% Capacity @ Indoor DB 80°F / WB 67°F

**Heating Mode Performance**

Rated Heating	12,000 BTU/hr
Ambient Range	-22~86°F
HSPF2 IV (V)	10.5 (9.0) BTU/W·h
COP2 (47°F)	4.0 W/W

Heating (17°F) = 14,000 BTU / Heating (5°F) = 12,000 BTU / COP2 (5°F) = 1.8 WW



Wall-Mounted Indoor Unit



Outdoor Condensing Unit



User-Selected Installation Kit



Handheld Remote Controller

**Electrical Information**

	Cooling	Heating
Rated Input (W)	970	925
Rated Current (A)	4.4	4.2
Breaker Needed	20A (Double-Pole)	
Power Supply	208~230V, 60Hz, 1Ph	

**Piping and Refrigerant**

Liquid Line (OD)	1/4 in
Suction Line (OD)	3/8 in
Refrigerant Precharge	R-454b(Supports 10-50ft.)
Max Length/Height Diff.	50 ft. / 33 ft.

This combination is Energy-Star certified.



**Interior Unit (Air Handler) Specifications**

Type	Heat Pump
Sound Level (dBA)	46 (Turbo)/ 44 (Hi)/ 36 (Med)/ 32 (Lo)/ 30 (Mute)
Auto Air Circulation	2-Way Louver (Up-Down + Left-Right)
Dimensions (WDH)	36-1/4 in x 7-5/8 in x 12 in
Weight (lbs)	23.1

**Exterior Unit (Condenser) Specifications**

Sound Level (dBA)	57
Recommended Room Size	350~500 Sq. ft.
Minimum Room Size	40 Sq. ft.
Compressor	Inverter-Driven Rotary
Dimensions (WDH)	34 in x 13-3/4 in x 23-3/4 in
Weight (lbs)	69.4

# WT012GLSI25HLH Air Handler Dimensional Data **PIONEER**

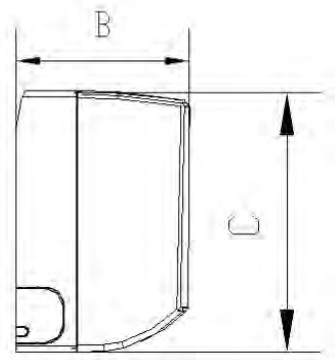
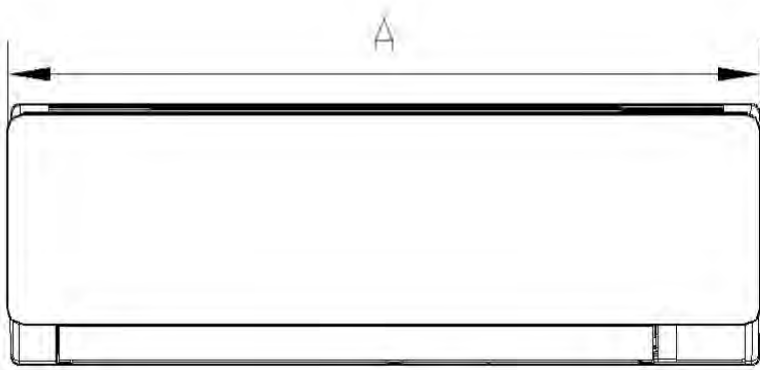
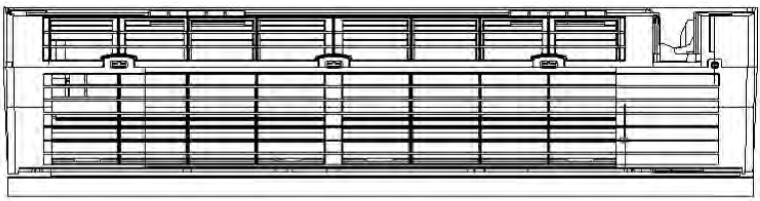

Model	A	B	C
WT012GLSI25HLH	36-1/4 in	7-5/8 in	12 in
	920.8 mm	193 mm	304.8 mm

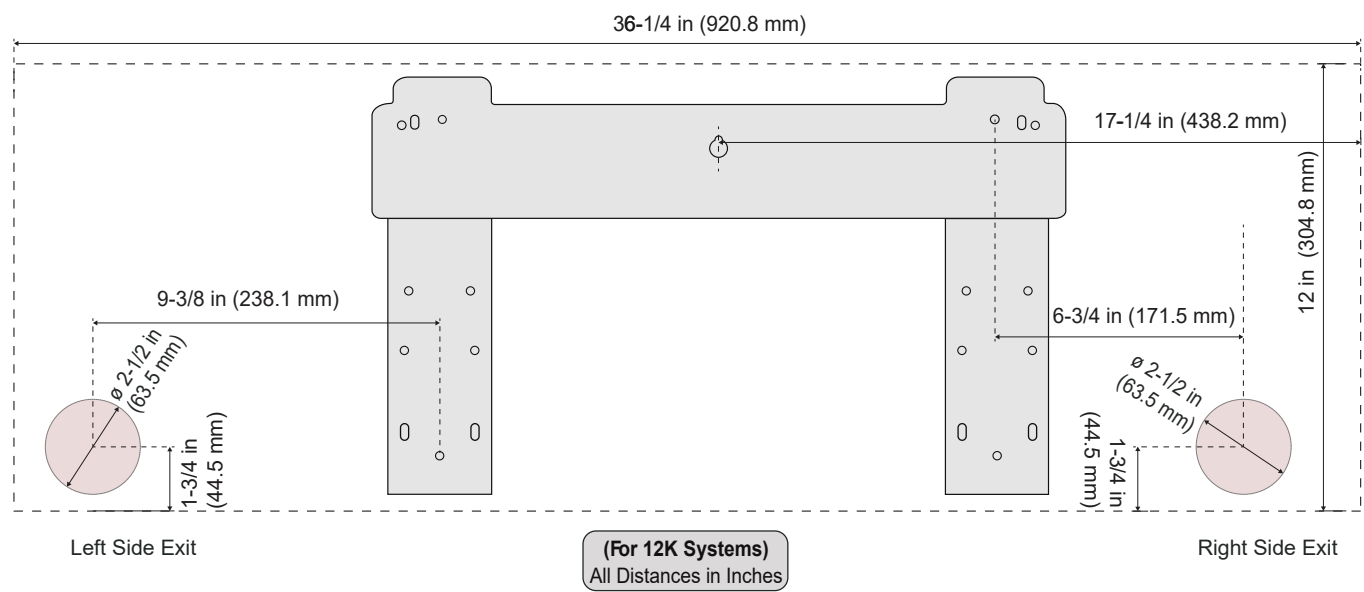

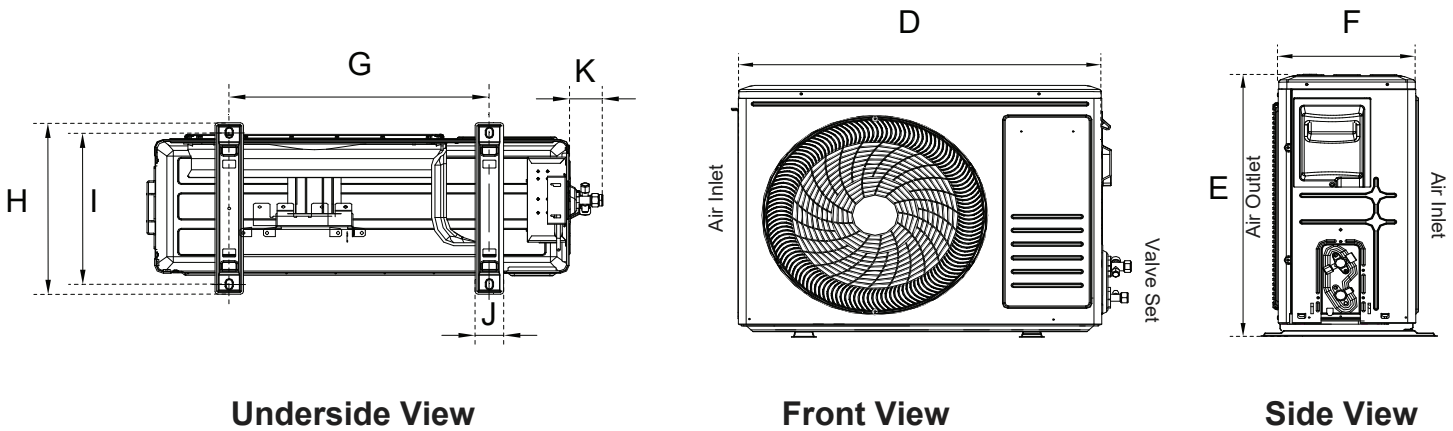

Model	D	E	F	G	H	I	J	K
YN012GLSI25RPH	31-1/4 in	23-3/4 in	11-3/8 in	20-3/8 in	13-3/4 in	12-3/8 in	2-1/8 in	2 in
	794 mm	602 mm	288 mm	516 mm	349 mm	314 mm	54 mm	51 mm

### Warranty Information and Length



Complete warranty details are available with the vendor or online at <https://www.pdhvac.com/support/warranty/>. This high quality system is eligible for up to 10 years limited warranty on the compressor, and 7 years on other internal parts. To qualify for this warranty, the system must be installed within 90 days by a registered technician. All other installations that are registered default to 5 years parts/compressor. Products unregistered qualify for only 1 year parts/compressor warranty.

### Outstanding Features

- LED Display
- Energy Saving
- Ultra-Thin Design
- Dual Drain Options
- Customizable Timer
- Eco-Friendly Refrigerant
- Whisper-Quiet Operation
- Power Loss Memory Recovery



### Available Accessories

Part Number	Description
IKT-LCVR4P-KIT	<i>Decorative PVC Line Cover Kit</i>
IKT-LNBR-1/4-3/8	<i>BendAid Flexible Easy Bender Kit</i>
BRK-FRM-C-2P	<i>Folding Mounting Bracket w/ Leveler</i>
IKT-UVL32UL-AG	<i>UVC Bacterial Disinfection Kit</i>
IKT-SURPRK-DV2	<i>Ultimate Surge and Power Protection</i>